



## BODY KIT SERIES for VW GOLF7 GTI >>> FRONT SPOILER with OPTIONAL FRONT SPLITTER



[iSWEEP Front Spoiler / Front Splitter]

VW GOLF7 GTI

◇ Parts List

1. Front Spoiler × 1
2. M4 Self-Tapping Screws × 8 pcs.

◇ **Optional Parts**

1. Front Splitter × 1
2. M4 Bolt, Nut, Washer × Two of each.

Thank you for purchasing iSWEEP products. This instruction manual provides necessary information for proper installation to prevent defects, malfunctions, and accidents from occurring. Please read and acknowledge all procedures before beginning installation. iSWEEP is not responsible for any injuries or death caused by the misuse or negligence of this manual and product.

### [Installation Instructions and Mounting Procedures]

This diagram shows the optional front splitter. If you did not purchase the front splitter disregard the splitter and install the four M4 tapping screws according to the diagram.

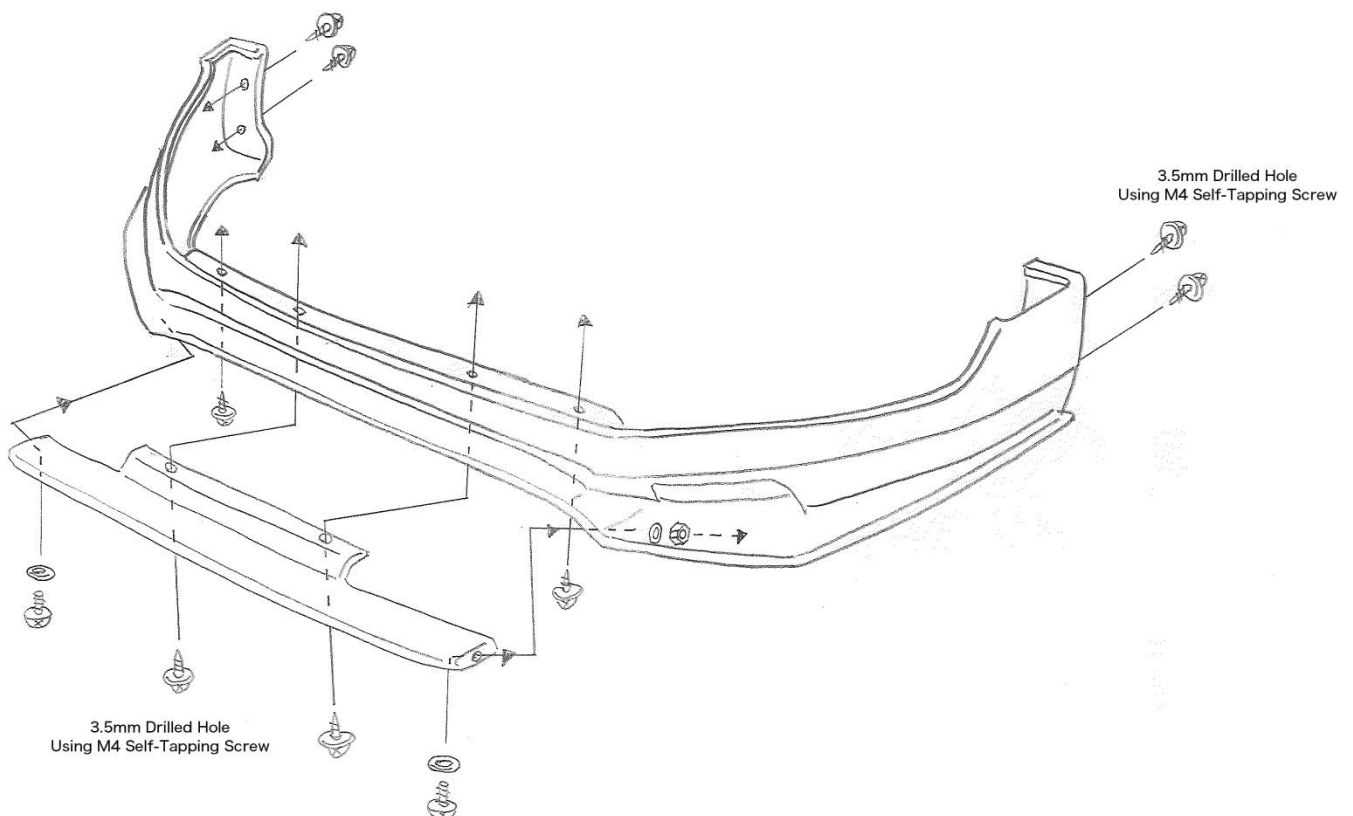

Turn page over

### 【Installing the Front Spoiler】

1. Remove the original front spoiler. Then check the mounting position on both sides of the iSWEEP Front Spoiler.
  2. This product should be taken to a body shop or paint refinisher and be painted by a qualified automotive paint specialist.
  3. Mark and drill four 3.5mm holes in the middle of the lip spoiler and two places at the fender arch as shown in the diagram.
  4. Please use the supplied M4 tapping screws to secure the front spoiler where the holes were drilled.
- ※Please see below for the optional splitter mounting instructions.

### 【Installation Guide】

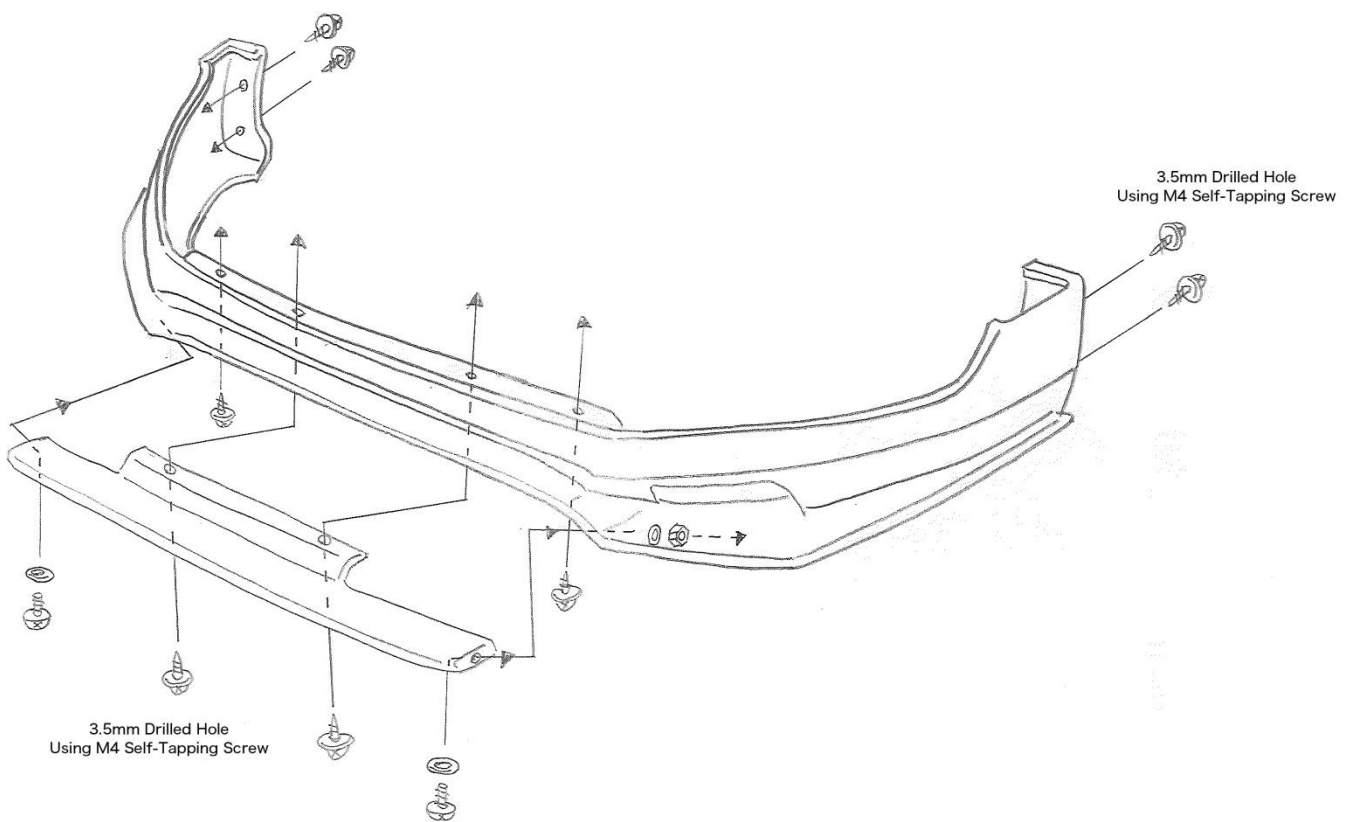

### 【Front Splitter】 \*Option

1. Two of the four screws securing the front spoiler will be used to secure the front splitter. And also two additional holes will be needed to be drilled opened.
2. Make sure the outer two screws of the front spoiler are tight then loosen the inner two screws and align the splitter . Then mark where you will need to drill the two outer edge holes that will connect the splitter and the spoiler. Do one at a time to make sure it is straight.
3. Remove the splitter and drill two 4mm holes where the marks were made.
4. Reattach the front splitter and use the included bolt, washer, and nut to secure the front splitter to the front spoiler.